

## 7.2.2 Exploded diagrams

Exploded diagrams of the equipment are shown below with reference to each component making it simpler to find the cause of faults and if necessary to substitute damaged parts.

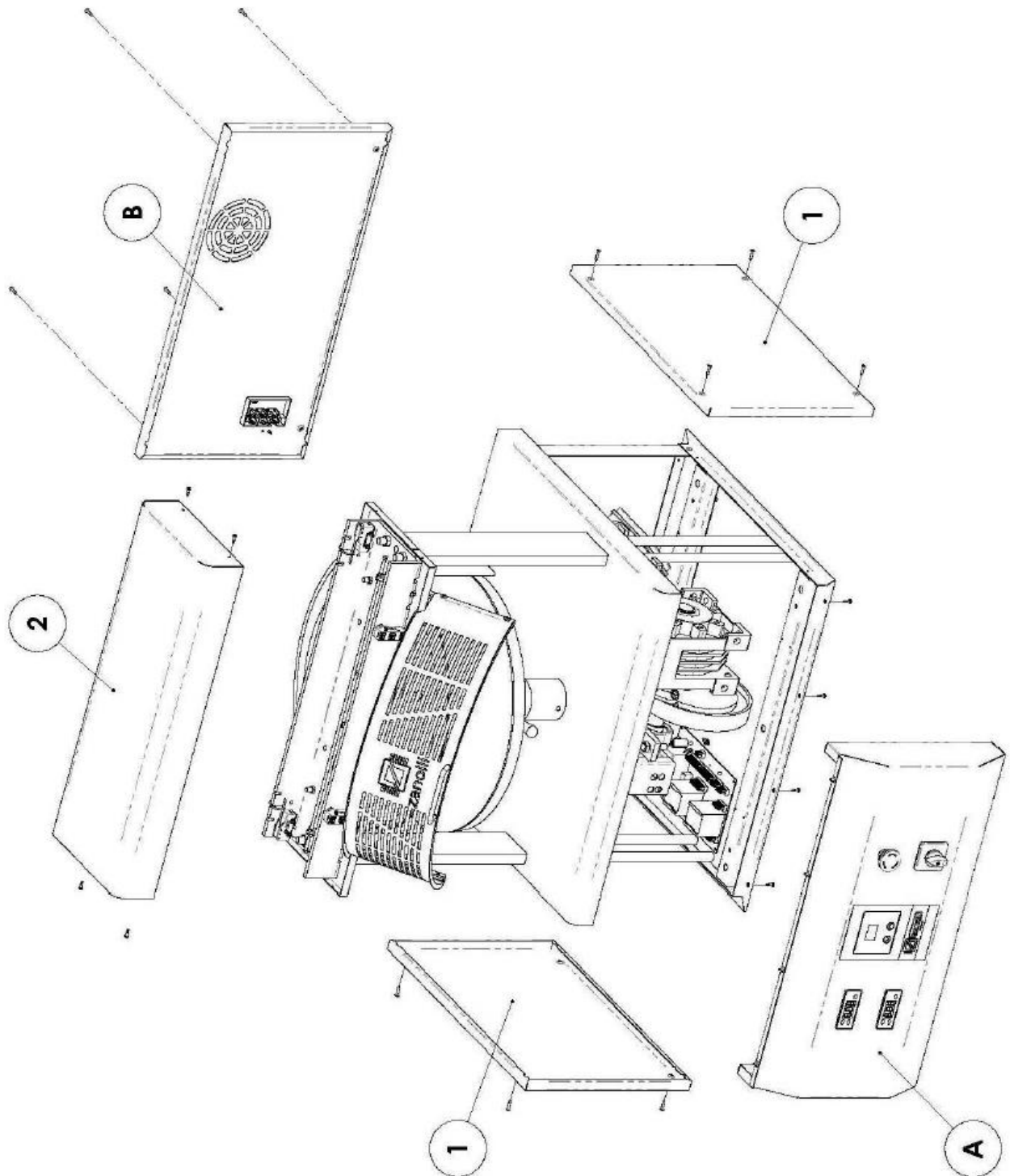

Fig. 7.1 DEVIL 33 / DEVIL 45 – exploded view

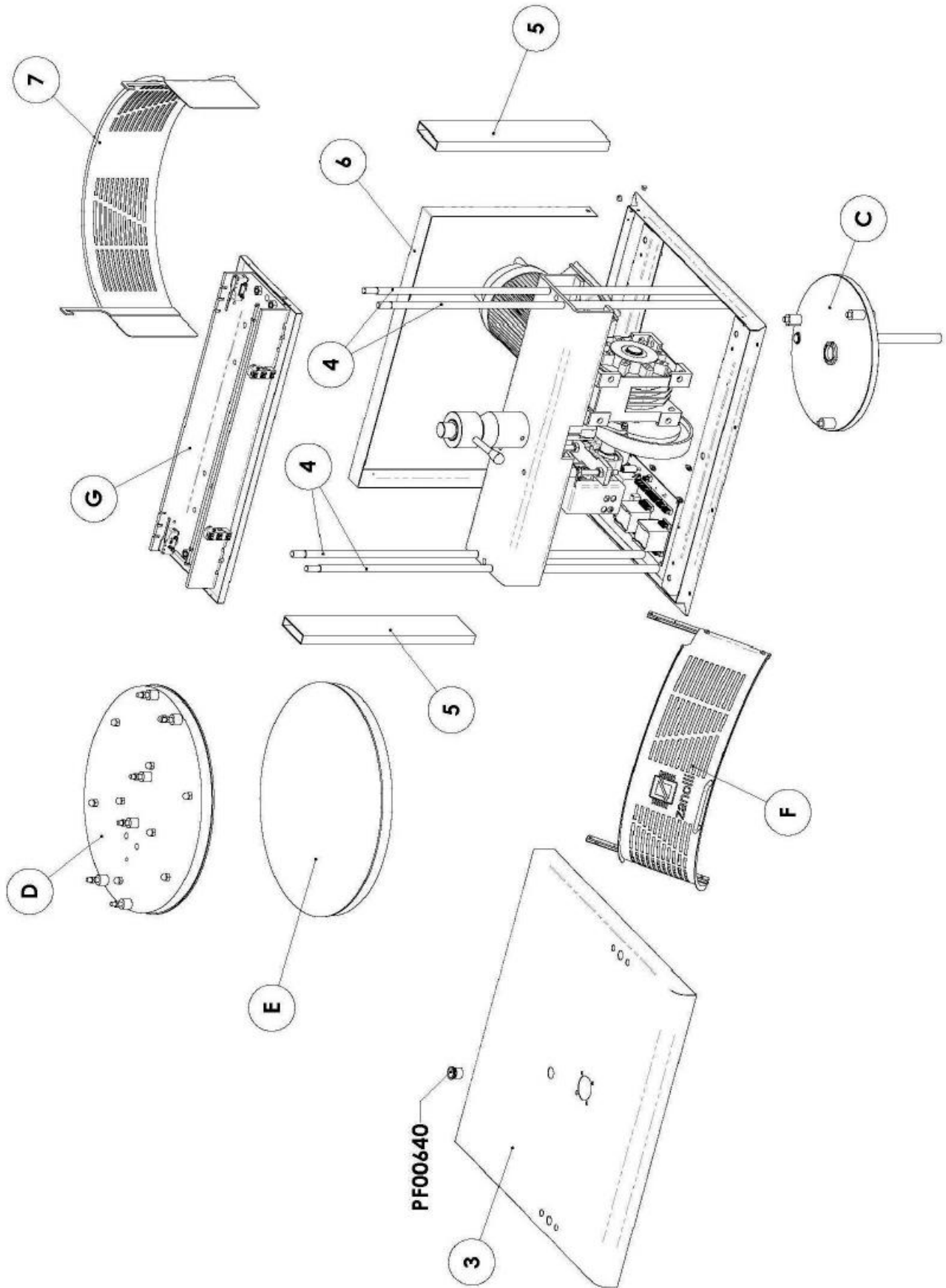

Fig. 7.2 DEVI 33 / DEVI 45 - exploded view

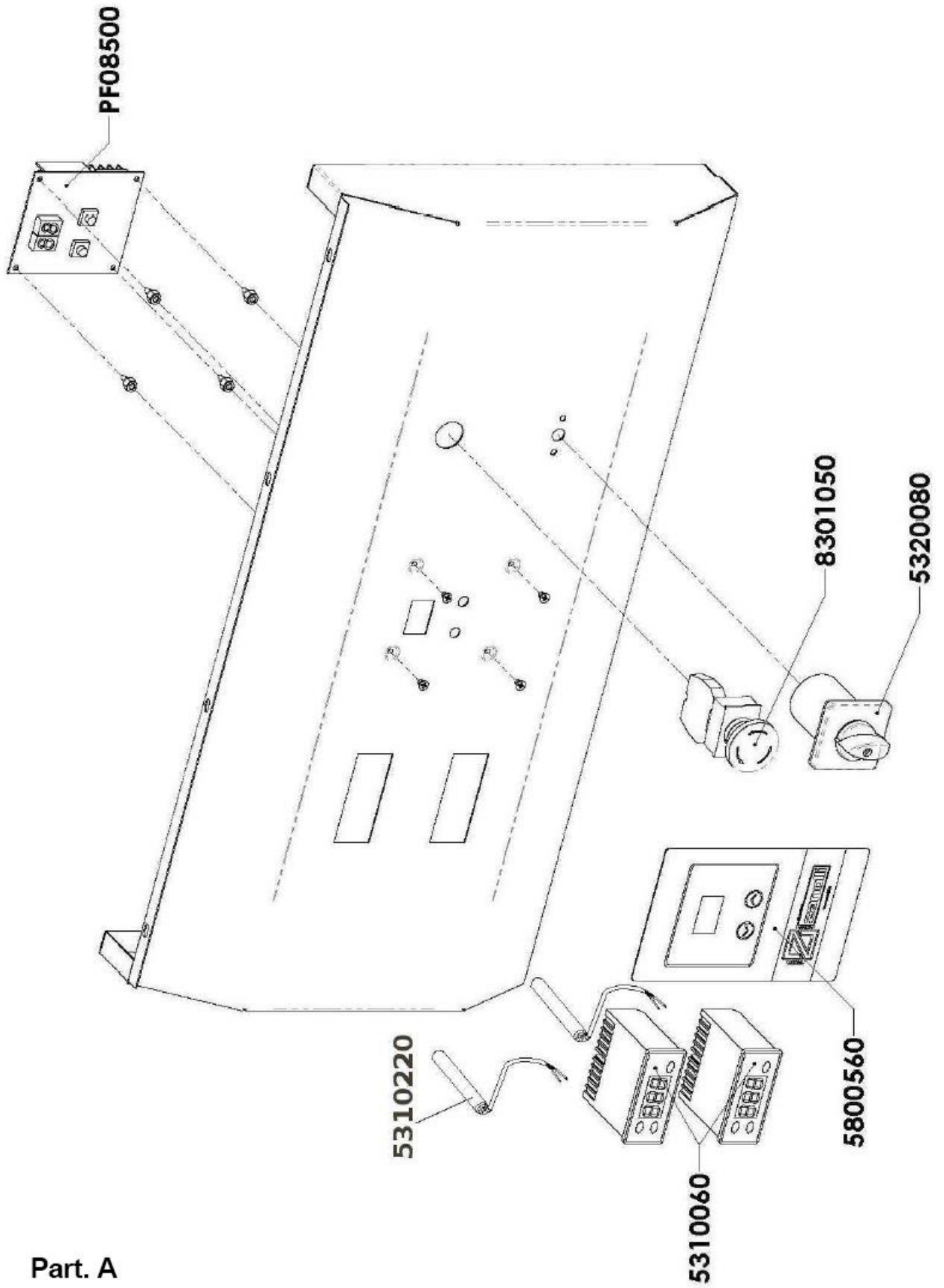
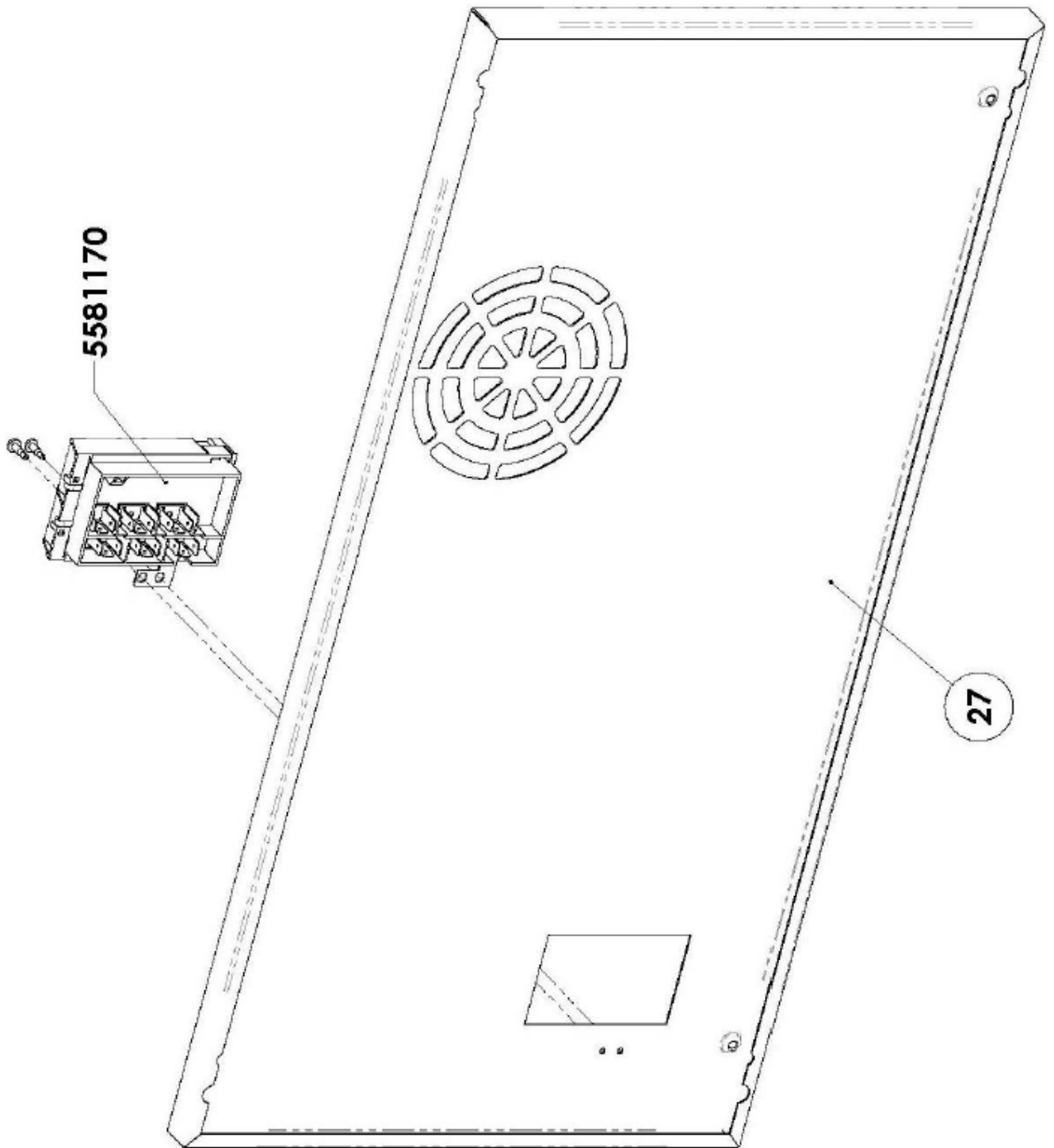
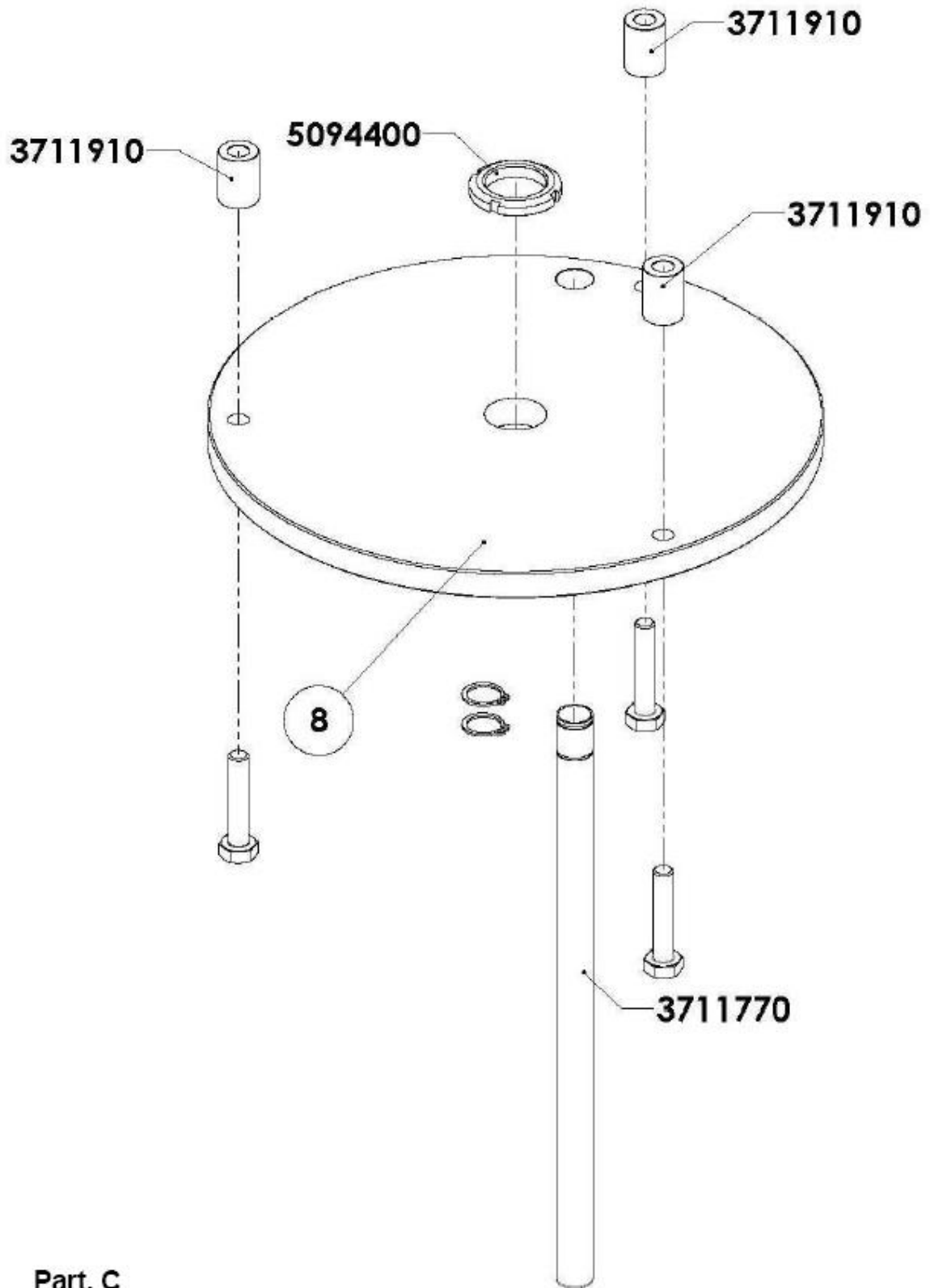

Fig. 7.3 Detail A



**Part. B**

Fig. 7.4 Detail B



Part. C

Fig. 7.5 Detail C

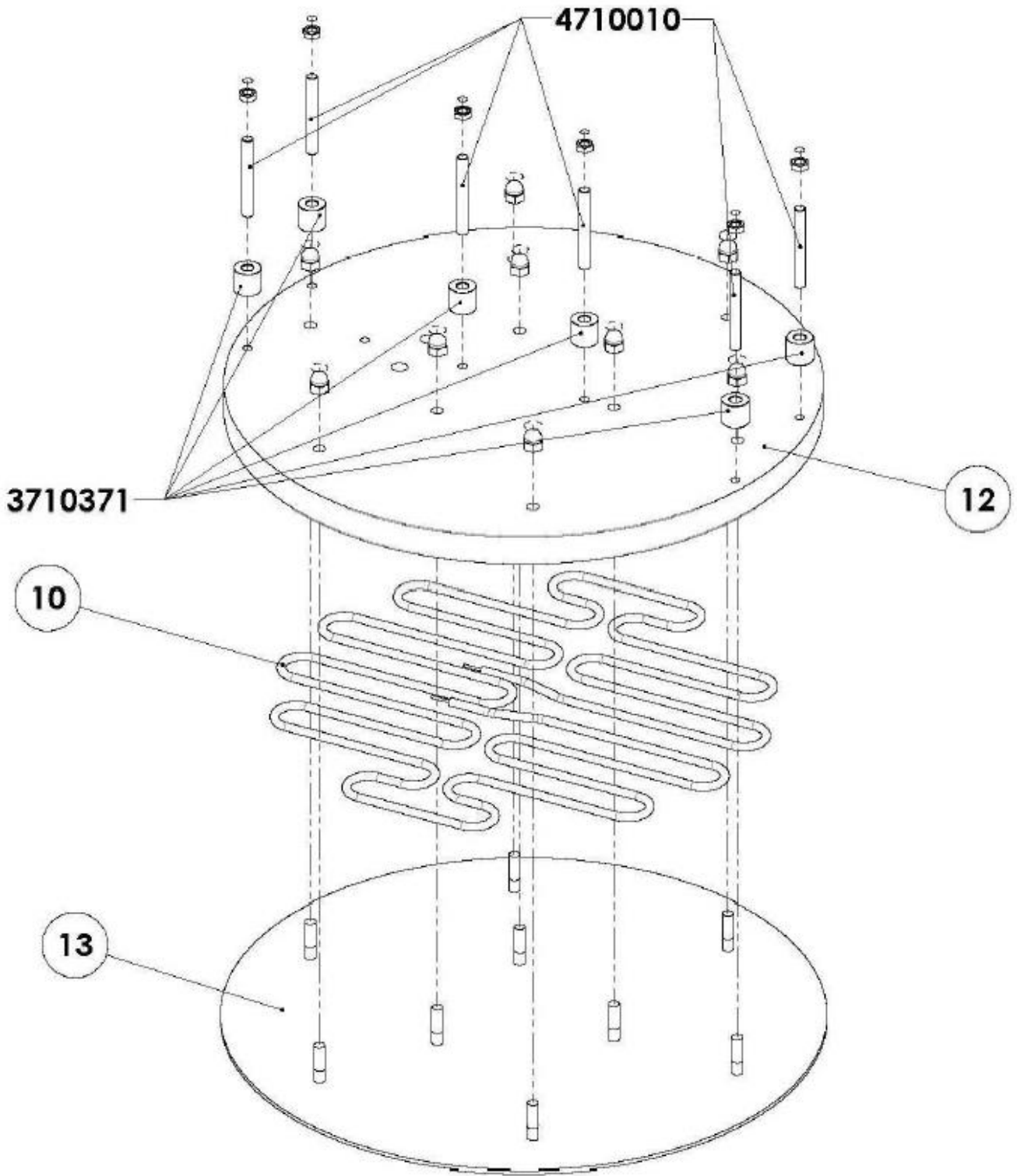

Part. D

Fig. 7.6 Detail D

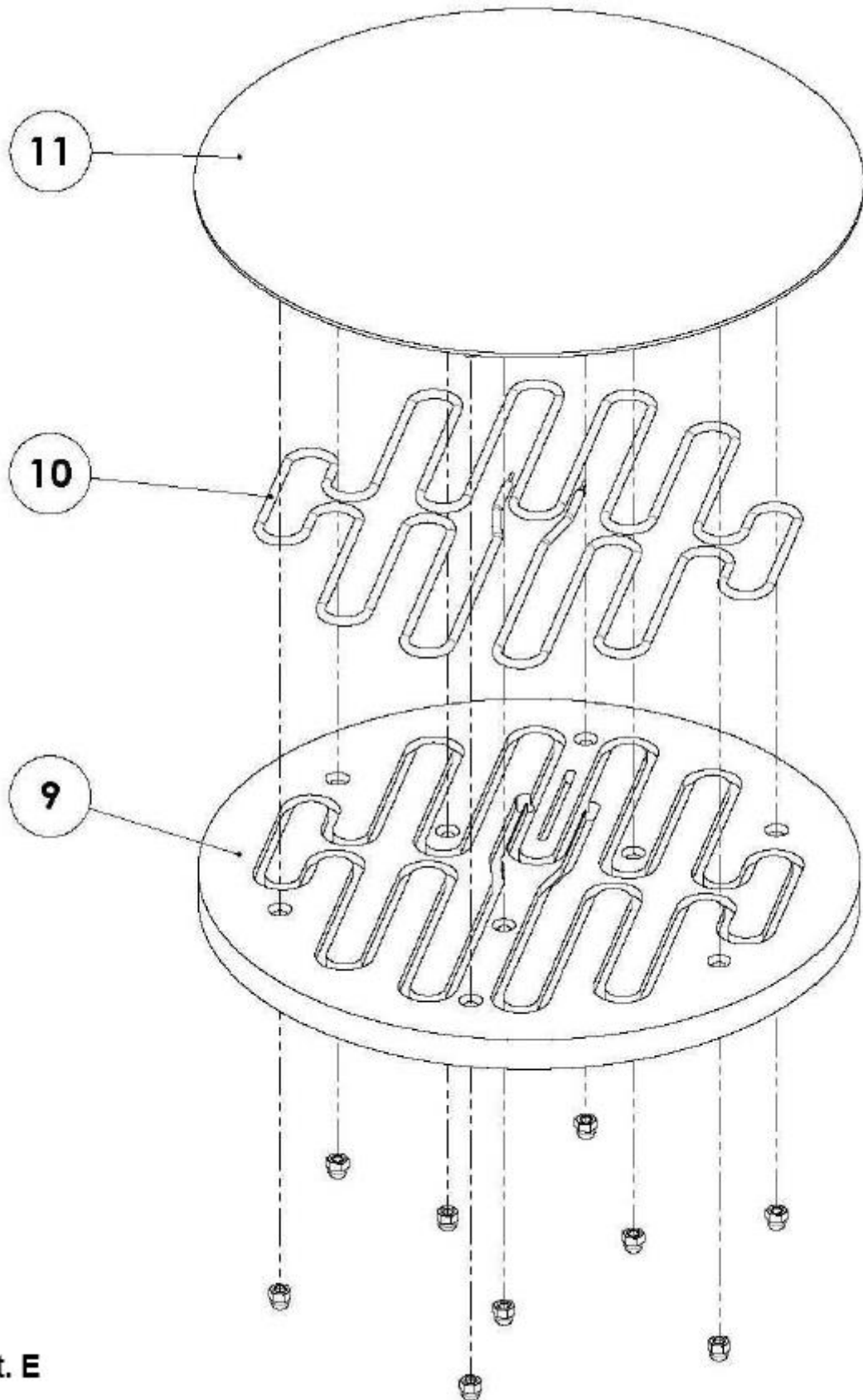

Part. E

Fig. 7.7 Detail E

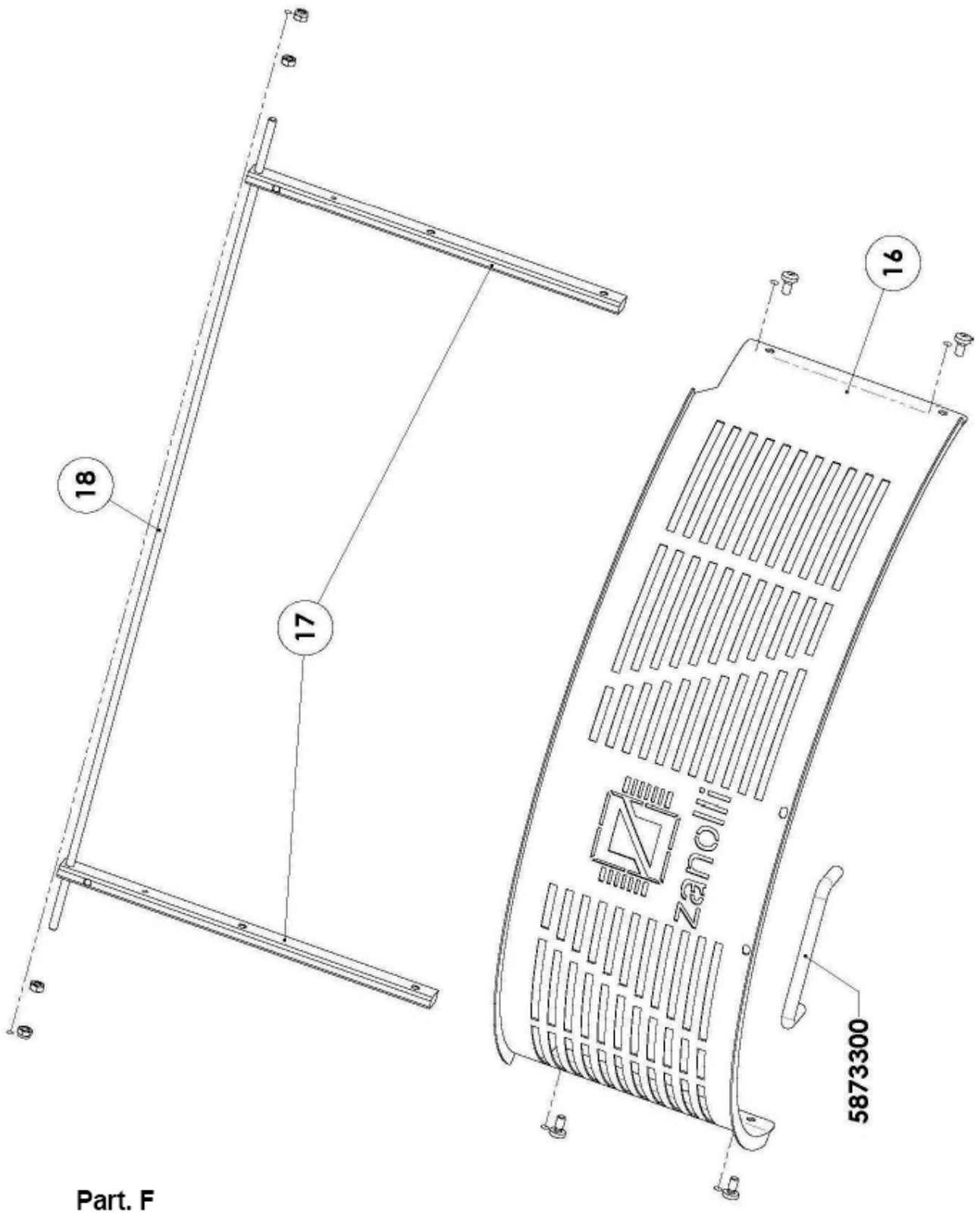

Part. F

Fig. 7.8 Detail F



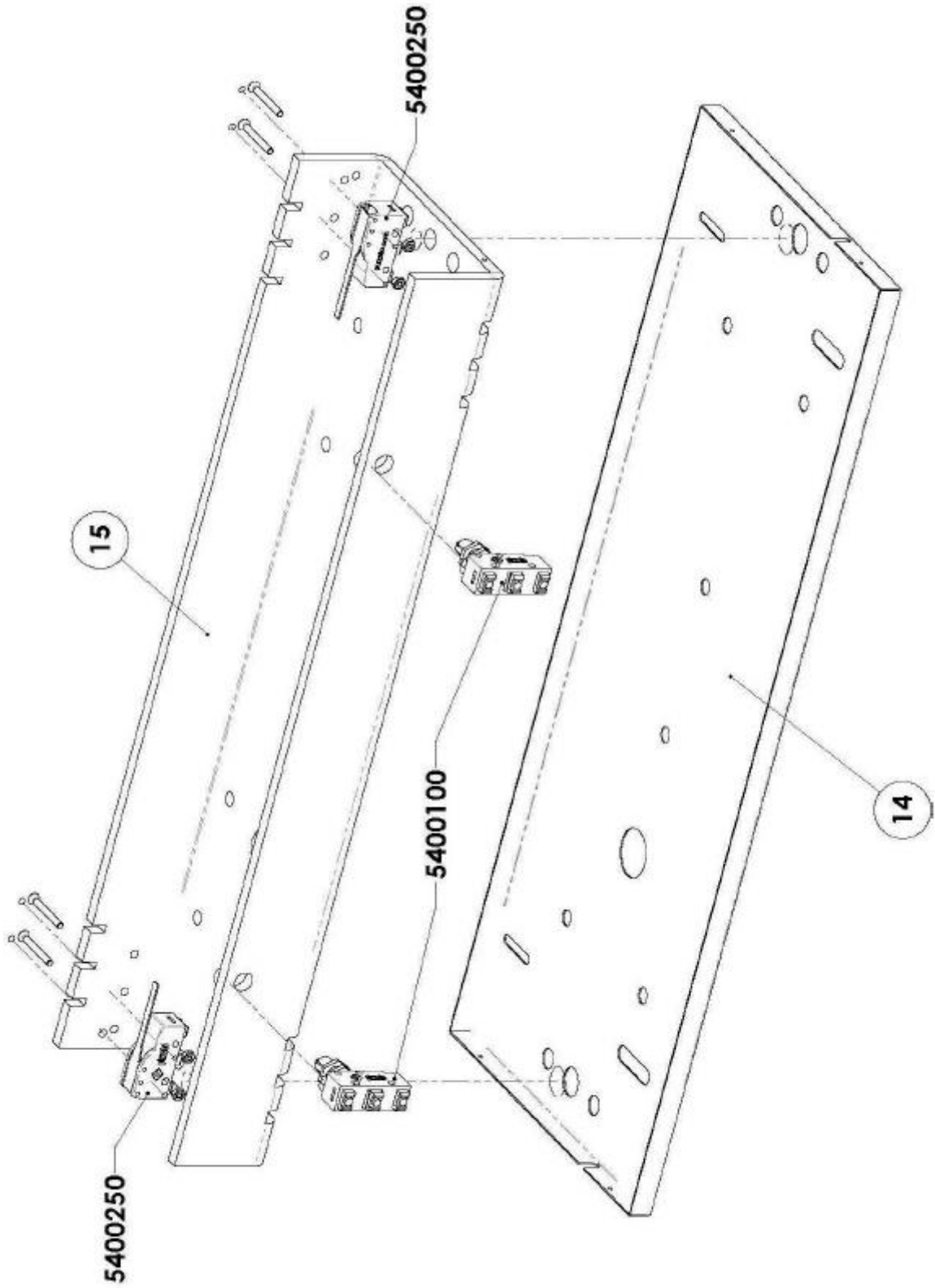

**Part. G**

Fig. 7.9 Detail G

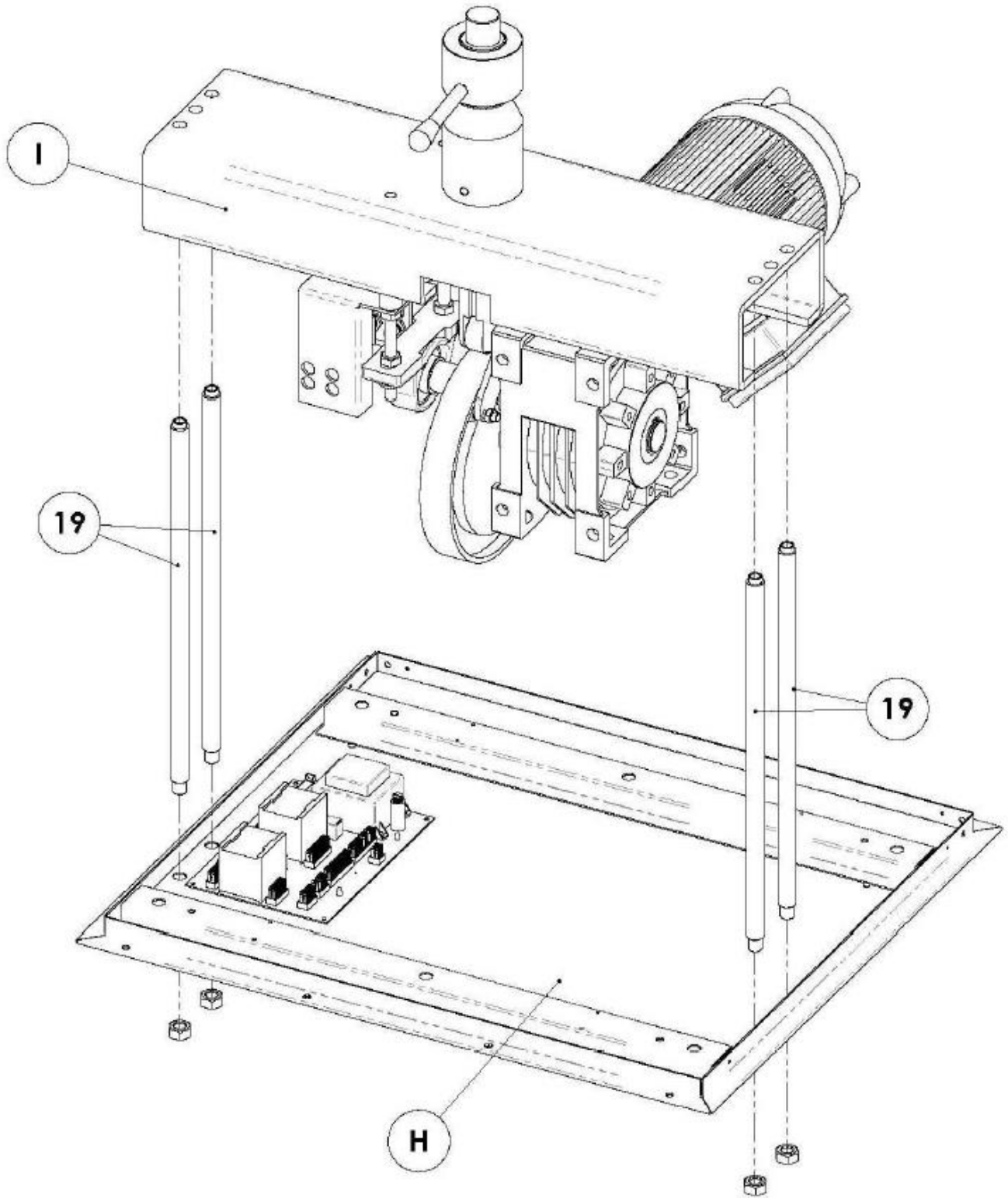
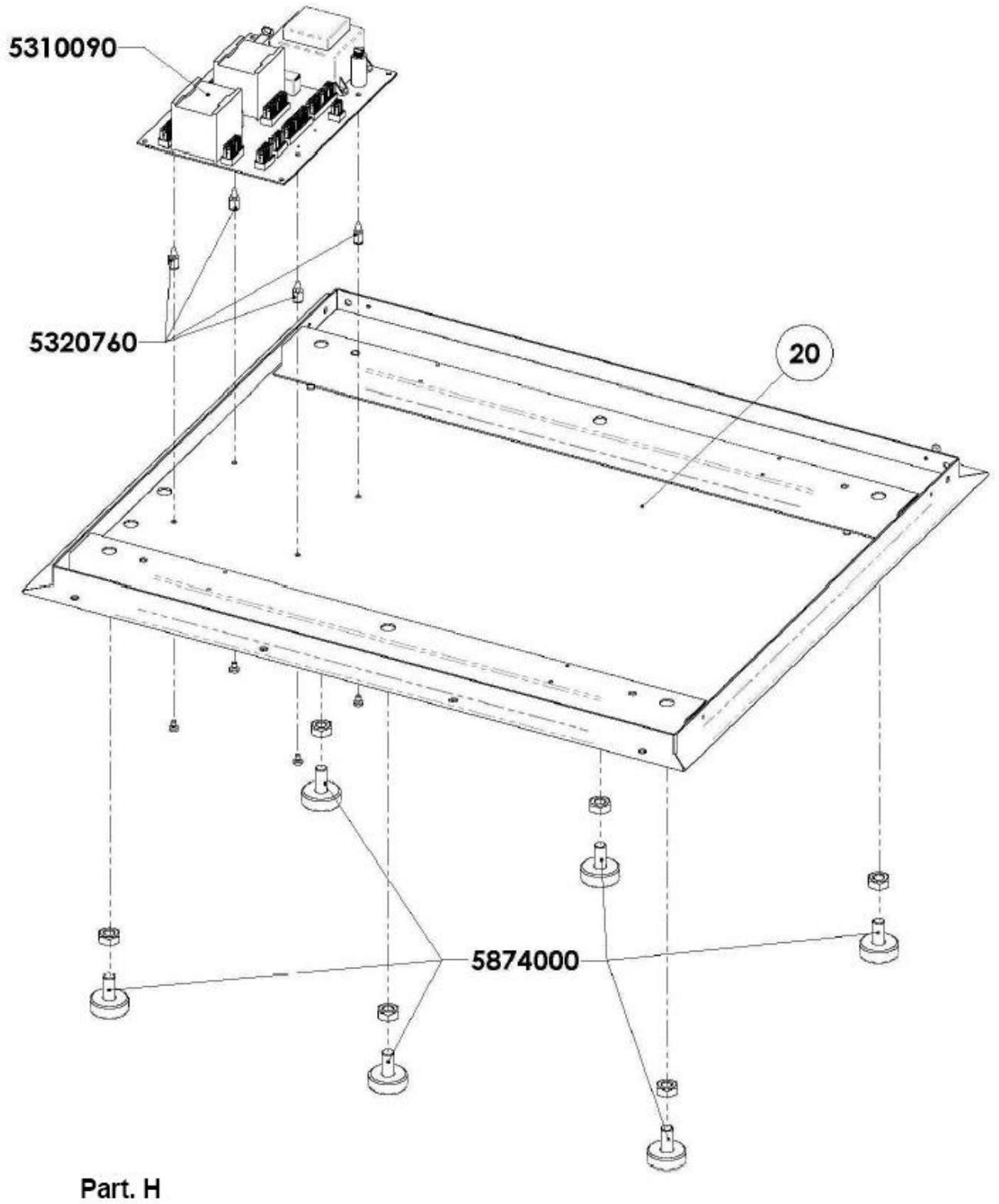
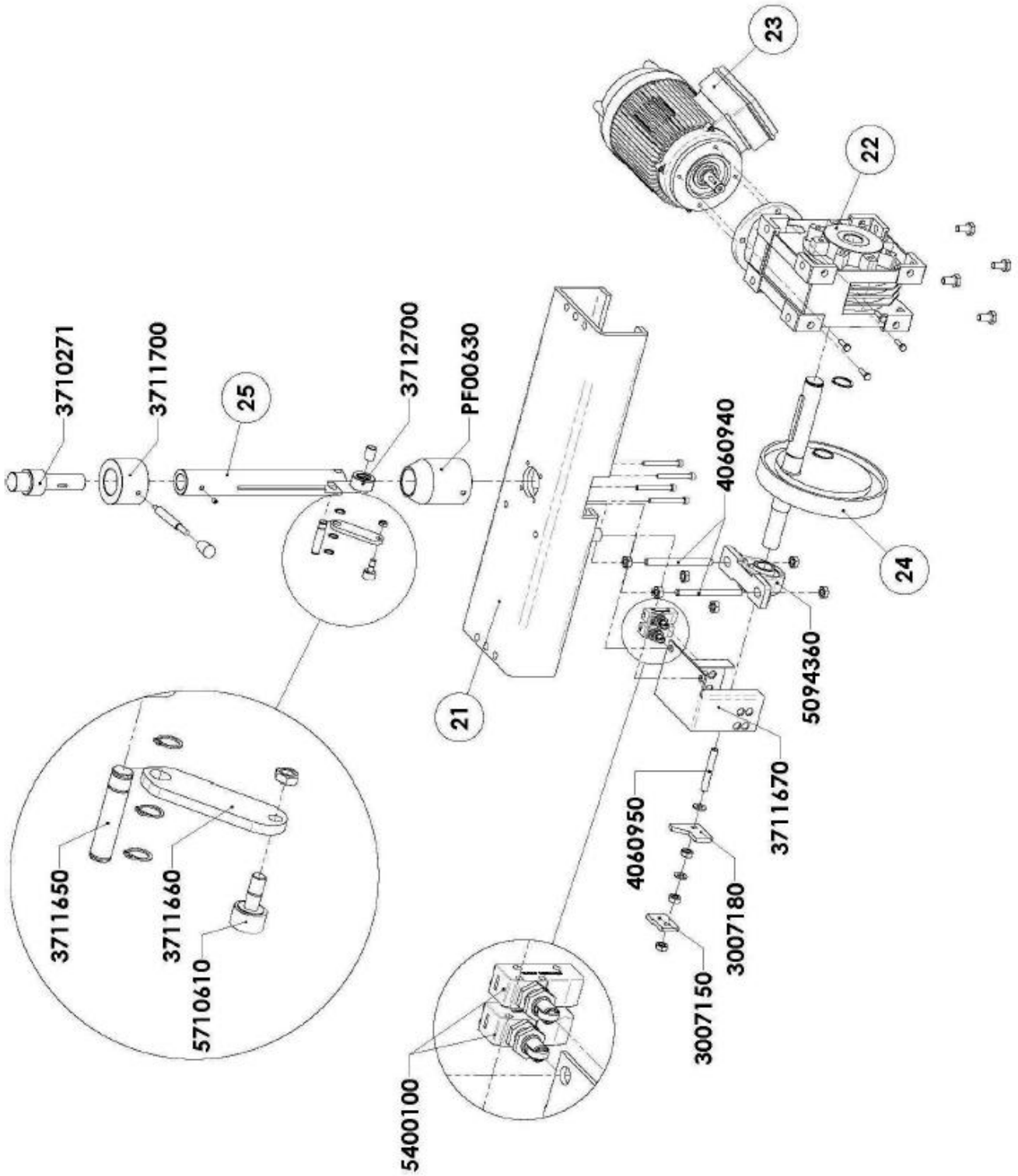

Fig. 7.10 DEVIL 33 / DEVIL 45 - exploded view



Part. H

Fig. 7.11 Detail H



Part. I

Fig. 7.12 Detail I

POS.	DEVIL 33	DEVIL 45	DESCRIPTION
1	3712310	3711960	Side panel
2	3712250	3711880	Cover
3	3712140	3711690	Upper part of casing
4	3712440	3712490	Upper column
5	3712450	3712500	Column spacer
6	3712100	3711620	Frame
7	3712470	3712520	Back protection
8	3712150	3711710	Lower disk support plate
9	3712340	3711980	Lower under-plate
10	5710120	5710130	Heating element
11	3711220	3711250	Upper under-plate
12	3712370	3711200	Lower plate
13	3711390	3711420	Upper plate
14	3712360	3712000	Cover base
15	3712640	3712610	Upper crosspiece
16	3712460	3712510	Front protection
17	3710210	3710220	Front protection fixing spars
18	3710690	3711840	Crosspiece for central microswitch
19	3712090	3711610	Lower column
20	3712080	3711600	Bottom assembly
21	3712630	3712600	Middle crosspiece assembly
22	PF08410	PF08400	Reducer
23	8303450	8300530	Electric motor
24	3711492	3711502	Complete camshaft
25	3712130	3710241	Vertical driveshaft
27	3712300	3711970	Back panel

Tab. 7.1. Components list DEVIL 33 / DEVIL 45

### 7.2.3 Wiring electric diagram

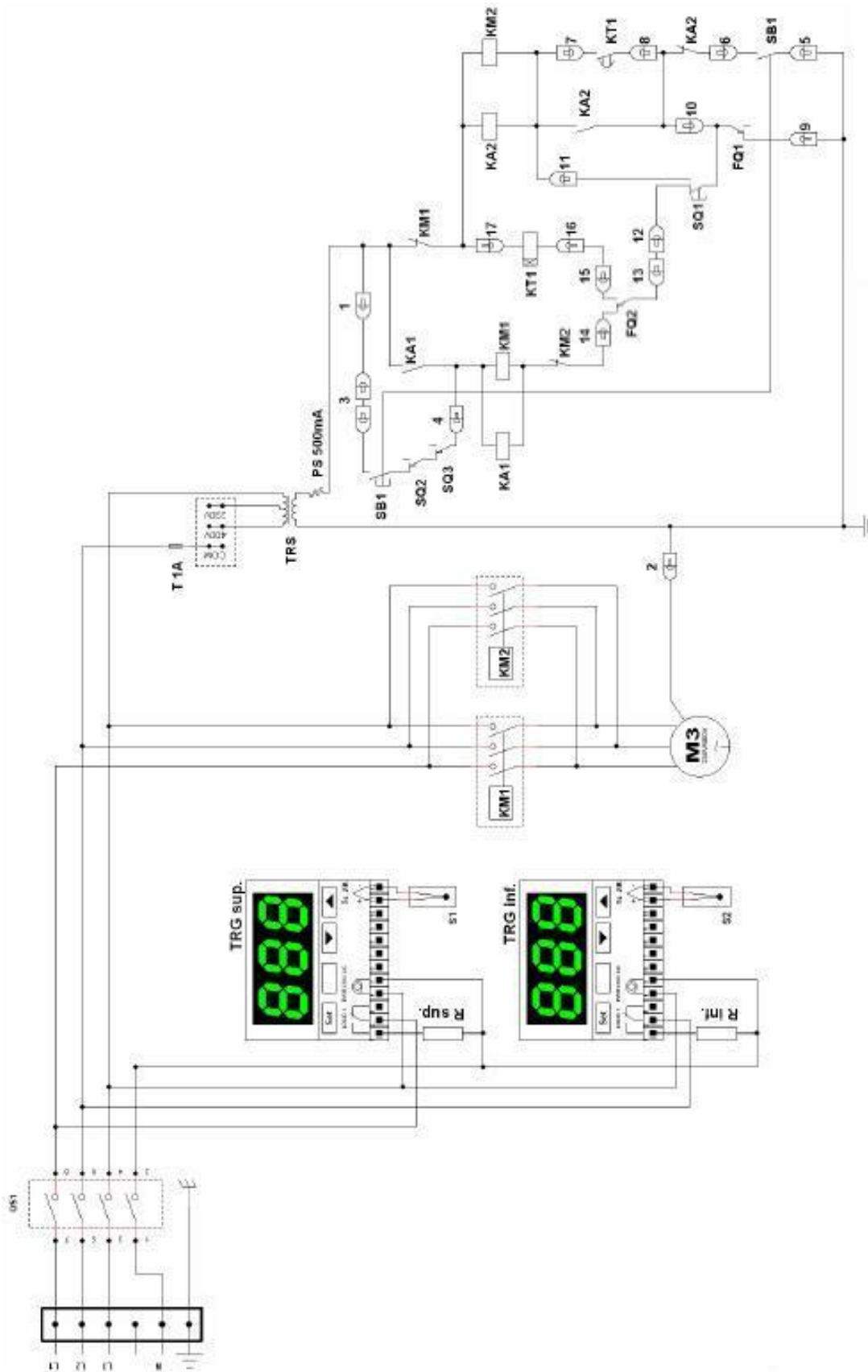

Fig. 7.13 Wiring diagram DEVIL 33 / DEVIL 45 - 400V 3N







<b>QS1</b>	Main switch
<b>TRG sup.</b>	Thermostat upper plate
<b>TRG inf.</b>	Thermostat lower plate
<b>R sup.</b>	Upper heating element
<b>R inf.</b>	Lower heating element
<b>S1</b>	Probe upper plate
<b>S2</b>	Probe lower plate
<b>KM1</b>	Raising control switch (integrated into circuit board)
<b>KM2</b>	Lowering control switch (integrated into circuit board)
<b>M3</b>	400V 3N – 50Hz electric motor
<b>T1A</b>	1A / 500V fuse (integrated into circuit board)
<b>TRS</b>	Transformer (integrated into circuit board)
<b>PS</b>	500 mA poliswitch
<b>SB1</b>	START microswitch
<b>SQ1</b>	EMERGENCY button
<b>SQ2 - SQ3</b>	Back grille position microswitch
<b>FQ1</b>	START/STOP limit positionswitch
<b>FQ2</b>	Raising limit positionswitch

Tab. 7.2 Table legend wiring diagram DEVIL 33 / DEVIL 45